

# Advanced polymeric composites with hybrid reinforcement

L. BEJAN\*, N. ȚĂRANU, A. SÂRBU

Technical University "Gh. Asachi" Iasi, B.dul Prof. D. Mangeron 67, RO-700050, Iasi, Romania

Hybrid composite materials, offer a larger variety of mechanical and thermal properties than standard composites as a result of the larger number of material parameters in the analysis and/or optimization of complex structures. Some ways of designing advanced woven hybrid materials emphasizing the choice of reinforcing and matrix components that enable the creation of composites with different stiffness properties include combinations of different fibre materials, variation of the number of counts, undulation in two orthogonal directions, and matrix characteristics. Hybrid woven fabrics made of fibres from E-glass, S-glass and Basalt have been embedded in polymeric matrices with different elastic moduli to obtain the most appropriate stiffness properties in the required directions.

(Received August 4, 2010; accepted September 15, 2010)

*Keywords:* hybrid reinforcement, woven fabric, textile polymeric composites, stiffness

## 1. Introduction

Composites are heterogeneous materials created by the synthetic assembly of two or more components constituting reinforcing and a compatible matrix, to obtain specific characteristics and properties which cannot be obtained by any constituent working individually [1]. Fiber reinforced composite materials represent a radical approach to designing structural materials when compared to traditional materials. The standard type of fiber reinforced polymer consists of a polymeric matrix in which one type of fiber is embedded. If two or more types of fibres are used, a hybrid material is generated.

A hybrid composite material can be obtained as a combination of two or more fibre materials in a predetermined geometry and scale, optimally serving a specific engineering purpose [2]. Consequently, hybrid composite materials, offer a greater variety of mechanical and thermal properties than standard fibrous composite materials. The layers may be composed of short fibres and long fibres embedded in a matrix under different architectures. Fibre reinforced composites exhibit quasi-isotropic or anisotropic behaviour, Figure 1, [3, 4].

Textiles are fibrous materials which are obtained by assembling the filaments into yarns and fibrous plies, and then into textile products. Woven textiles are structured materials and their diversity comes from special technologies resulting in a large variety of available textile structures that are widely used as reinforcements for composites. The properties of a fabric are the properties of fibres transformed by the textile structure.

In contrast to composites reinforced with unidirectional fibres the geometry and structure of textile composites is much more complex. Mechanical properties of textile composites are influenced by several parameters and phenomena such as fiber architecture or internal

geometry of fabric, number of counts, size of gap, height of woven layer, undulation and thickness of composite lamina. Each of these can influence the structural behaviour, but can only be modelled on its specific length scale [5].

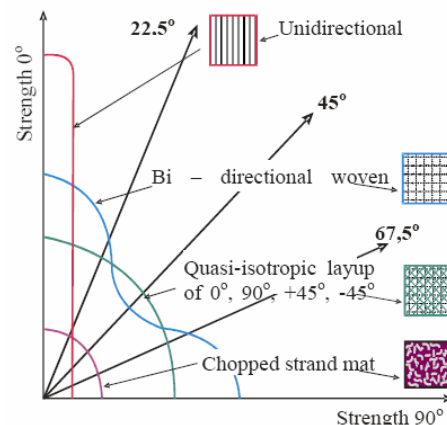

Fig. 1. Variation of mechanical properties with loading direction.

## 2. Hybrid reinforcement

Unidirectionally fibre reinforced composite materials can be designed to meet the specific requirements of a particular application using many available variables (the choice of constituents and their volume fractions, reinforcement orientation and manufacturing process). The maximum values of mechanical characteristics are obtained in the fibres direction; when high values are needed in two perpendicular directions the use of balanced and/or unbalanced woven fabrics is recommended.

However there are still domains of properties “uncovered” by such solutions and the “hybridization” process is a welcome solution.

A hybrid reinforcing material can be defined as a combination of two or more materials in a predetermined geometry, orientation and scale, optimally serving a specific engineering purpose. Additional property values are generated and these new variables expand the design space, allowing an optimization of properties that is not possible if choice is limited to single, monolithic materials. Different combinations of materials and of their associated properties to reach values unattained with individual materials can be achieved using the paths A, B, C and D shown in Figure 2. A corresponds to the peak values of properties  $P_1$  (of material  $M_1$ ) and  $P_2$  (of material  $M_2$ ). Each path can be formulated and characterized by linear (A,C,D) and/or non linear (B) analytical models [6].

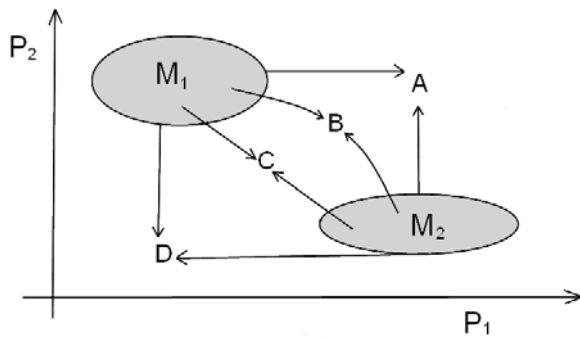
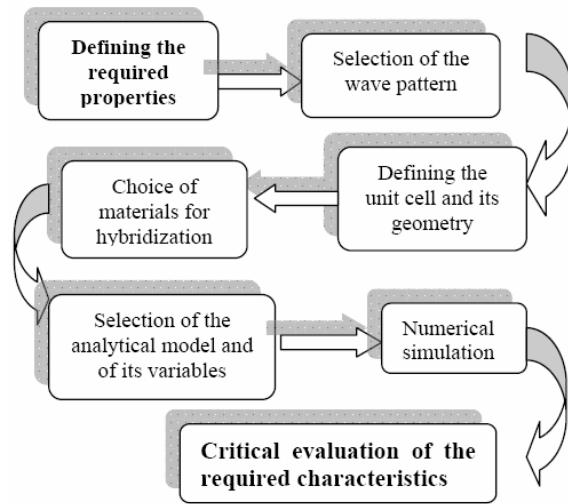

Fig. 2. The possibilities of hybridization

Textile composites have mechanical properties different from those of unidirectionally reinforced composites. The use of woven fabric as reinforcement in polymeric composite materials continues to expand in structural applications. Mechanical properties of such composites are highly influenced by the details of fabric architecture. The fabric architecture depends upon the undulation of the yarns, yarn crimp degree, density of the yarns and number of counts. The geometry of the woven composites is complex and the choice of possible architectures is practically unlimited. The undulation or waviness of the yarns causes bending in the yarns, which reduces the mechanical properties of the composite. Such effects can be overcome by hybridization that compensates the loss of rigidity due to crimp influence. However the hybridization further complicates the analysis by introducing new variables. Most analytical models to determine the composite lamina stiffness are based on micromechanics analyses on representative unit cells that are different for every weave pattern.

The following design and analysis steps have been proposed by the authors to make the best use of hybridization in achieving the design properties:



### 3 Plane wave fabric reinforcement

#### 3.1 General

Weaving is one of the major textile forming techniques for woven fabrics utilised for polymeric composites reinforcement.

A plane wave fabric is made of two different systems of interlacing yarns termed warp and fill that define the basic structure of the plane wave fabric. This type of fabric is characterized by linear densities of warp and fill yarns, a weave pattern, a number of warp yarns and fill yarns per unit width or unit length, warp and fill yarn crimp, and surface density.

Orthogonal fabrics exhibit good dimensional stability in the warp and fill directions. Woven fabrics offer the highest yarn packing density in relation to fabric thickness. The pure and hybrid woven fabrics used in composites are mostly in the form of plain, basket, twill and satin weaves [7].

The mechanics of plain-weave composites is set apart from that of straight fiber composites by large local deformation effects. Depending on the application requirements the hybrid plane wave fabric used as reinforcement can be optimized using two different isotropic materials in the orthogonal directions or combinations of different anisotropic materials. The compatibility of materials for reinforcing fibres in terms of deformability, thermal properties and drape ability is essential in an efficient hybridization of woven fabrics.

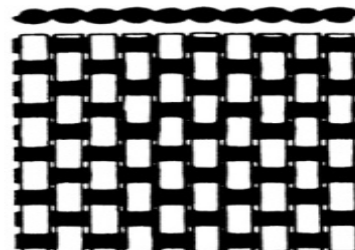

Fig. 3. Plain weave fabrics.

### 3.2 Lamina configuration

The fabric geometry should be chosen so that it should give the best possible properties for the application under consideration. The important fabric parameters are yarns cross-sectional geometry, finesse, number of counts and the weaving condition such as balanced or unbalanced. . Linear density of the yarn is the mass per unit length, which is a measure of finesse of the yarn and it is given by the tex number in [g/km]. The most important parameters that influence the composite stiffness considered in this hybridization simulation are:

- the fabric count is the number of yarns per unit length along the warp ( $n_1$ ) and fill direction ( $n_2$ ).
- the yarn crimp which is a measure of the degree of undulation; the undulated length within the interlacing region is termed “ $u$ ”.

A plain weave fabric can be balanced or unbalanced depending upon the number of counts and yarn properties in two orthogonal directions. If the yarn properties such as cross-sectional geometry, tex, crimp, the number of counts and the material properties are the same in both directions (warp and fill) the fabric is called balanced fabric.

The unbalanced fabric can be used if different properties are required along the warp and fill directions.[2], [4].

The elastic behaviour of woven fabric composites depends upon the type of weave fabric geometry, fibre volume fraction, laminate configuration and the material system used.

Plain weave orthogonal fabric is the simplest fundamental weave with repeat size  $N=2$  and step  $s=1$ , and consists of two sets of interlaced yarns, Figure 3. The lengthwise set is called warp, and the crosswise set is termed fill. Any weave repeats on certain number of warp and fill yarns is defined by geometrical quantities  $n_1$ , and  $n_2$ . The repeat is a complete representative unit cell of weave, illustrated in Figure 4, [7, 8].

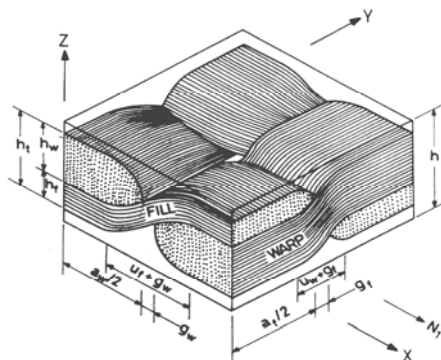

Fig.4. The unit cell of plain weave fabric.

In this paper, the authors analyze a hybrid 2D orthogonal plain weave lamina in which the warp and fill fibres materials are different. Combinations of three isotropic fibres (E-glass, S-glass and Basalt) in a plane

wave embedded in thermosetting polymeric resin are studied. The main properties of the fibres and matrix utilized for hybrid textiles composite lamina are given in Table 1.

Table 1.Elastic properties of fibres and matrix

Material	E (GPa)	G (GPa)	$\nu$
Polymeric matrix	2.75...4.25	1.08...1.43	0.36...0.40
Basalt fibre	89	37.08	0.20
Glass E fibre	72.4	29.67	0.22
Glass S fibre	85.5	35.0	0.22

The fabric was assumed to be a closely woven plain weave with an overall fiber volume fraction equal 0.39. The geometrical characteristics of the woven composite lamina are given in Table 2.

Table 2.Geometry of lamina composite.

$h_t=h$	$u_w / u_f$	$a_w / a_f$	$g_w/g_f$
0.5	0.50 / 0.80	1.44/1.12	0.12/ 0.6

where

- $h$  represents the composite lamina thickness
- $h_t$  represents the plane woven fabric thickness
- $a_w, a_f$  represent the dimensions of warp and fill yarn in the representative unit cell
- $g_w, g_f$  represent the gap between two adjacent yarns
- $u_w, u_f$  represent the undulation of fiber in both directions.

The number of counts  $n_1$  of warp has been considered variable, from 3 to 7, while the number of fill counts  $n_2$  has been kept constant and equal to 3, [8]. This selection of the number of counts enables both the evaluation of the composite moduli for balanced fabric (3x3) and the influence of the unbalancing degree, up to (3x7). For balanced fabric the increased stiffness is given by the use of different reinforcing materials while in case of the same reinforcing material the variation of stiffness is caused both, by the material and the unbalancing degree.

The objectives consisted in analyzing the influence of different types of isotropic fibres on the lamina stiffness with respect to various parameters such as matrix stiffness, the number of counts in warp and fill directions as well as the crimp degree expressed by undulation.

### 4. Case studies

Many analytical models exist for the calculation of average stiffness matrices of textile laminates, but almost all do not consider the effect of crimp. In this paper the utilized model transform the unit cell in two elementary sub-lamina that take into consideration the undulation on both directions, Fig. 4.

Two types of plain wave textiles have been analyzed: one unbalanced fabric with the warp number of counts equal to 7 and a constant fill number of count equal to 3,

the second type of reinforcement is a balanced fabric with 3 counts in both directions.

A special simulation setup was developed in Microsoft Visual C++ 6.0 IDE, [9, 10]. This application allows establishing different sets of variable parameters and their evolution as well. Unfeasible practical combinations of parameters or those which imply obtaining unrealistic characteristics of the simulated structures are excluded automatically. The simulation data have been stored in adequate organized files to be further processed [10].

The composite lamina with a polymeric matrix with average properties has been successively reinforced with six fibre combinations as it follows:

- Case 1. Glass S (warp) - Glass E (fill)
- Case 2. Basalt (warp) - Glass E (fill)
- Case 3. Basalt (warp) - Glass S (fill)
- Case 4. Glass E (warp) - Glass E (fill)
- Case 5. Glass S (warp) - Glass S (fill)
- Case 6. Basalt (warp) - Basalt (fill)

The selected elastic module of the matrix for this simulation corresponds to the most utilized thermosetting polymeric resins in structural applications (epoxy, polyester, vinyl ester, phenol). However, having in mind the negligible effect of matrix on the lamina stiffness, only an average value of matrix modulus (equal to 3.25 GPa characterizing all mentioned matrices) has been utilized in our graphical representations.

The main results obtained from numerical modelling are illustrated in Figs. 5-7. In Fig. 5 the hybridization effect is produced by replacing the reinforcing fibre material in the warp direction with a new material having a much higher elastic modulus compared to the initial one (E-glass fibre has been successively replaced by S-glass fibre and Basalt fibre). An increase of 17.22% has been obtained for the balanced fabric (3x3).

An additional increase of the hybridization effect, equal to 25% in case of E-E glass, 26.75% for E-S glass and 27.17% in case of E-glass-Basalt fibres has been achieved by increasing the number of counts (from 3 to 7) in the warp direction.

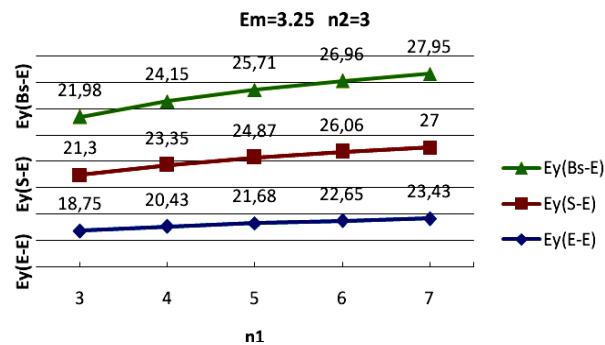

Fig. 5. Influence of hybridization on the elastic modulus (E<sub>y</sub>) in the warp direction.

It can be noticed from Fig. 6 that a small increase of the elastic modulus E<sub>x</sub> occurs for balanced fabric, without changing the fibre material; however an marked decrease of E<sub>x</sub> occurs due to the increase of the unbalancing degree (from 3 to 7 counts).

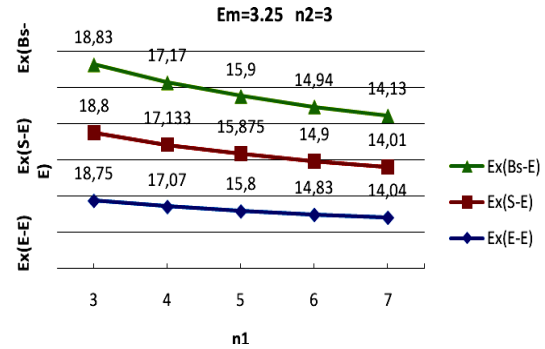

Fig. 6. Influence of hybridization on the elastic modulus (E<sub>x</sub>) in the fill direction.

In case of woven fabrics the stiffness along warp direction can be also slightly modified by changing the fibre material in the fill direction. This influence can be visualised in Figure 7 where the reinforcing fibres in the fill direction have been replaced as indicated on the graphs axes. This small increase is caused by so called “lateral” effect of reinforcing fibres.

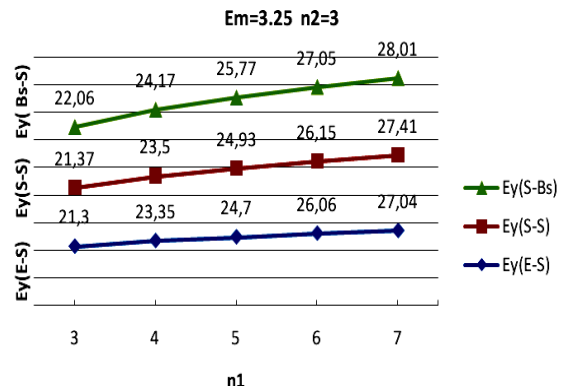

Fig. 7. The “lateral” effects of changing the fibre materials.

### 5. Conclusions

Textile composites are valuable composite products with significant advantages in different areas of utilization. The nature of material for reinforcing fibres has a substantial effect on the stiffness properties of textile composites. However the crimp effect due to weaving decreases the stiffness in all directions of the composite product. A hybridization procedure has been proposed and

analysed in the paper to overcome this disadvantage and further improve the textile composites performance. Depending on the product requirements the stiffness can be modified in the main geometric directions by the pattern of the fabric and/or the types of fiber material. In addition, a certain modification in stiffness characteristic may be obtained through variation of the matrix material and its elastic moduli.

### Acknowledgement

This work was supported by CNCSIS - UEFISCSU, project number 737, PNII - IDEI code 369/2008 on hybrid structures made of polymeric composites and traditional building materials.

### References

- [1] G. Lubin, Handbook of Composites, New York, Van Nostrand, (1982).
- [2] J. Hult, Hybrid Composite Materials, Lectures notes, Courses in Engineering Mechanics of Fiber Reinforced Polymers and Composite Structures, 4-th IUTAM International Summer School on Mechanics, CISM, Italy, (1993).
- [3] B. A. Strong, Fundamentals of Composites Manufacturing. Materials, Methods and Applications, Society of Manufacturing Engineers, (2008).
- [4] R. Rolfes, G. Ernst, M. Vogler, C. Huhne, Springer, pp.27-54, Editor Camanho, P., Davila C., G., Pinho, S.T., Remmers J.J, (2008).
- [5] L. Bejan, N. Taranu, J. Optoelectron. Adv. Mater. **9**(9), 2902(2007).
- [6] M. F. Ashby, Y. J. M. Brechet, Acta Materialia **51**, 5801 (2003).
- [7] N. Naik, Woven Fabric Composites, Technomic Publishing AG, Basel, Switzerland, (1994)
- [8] L. Bejan, A. Sarbu, N. Taranu, Revista Materiale Plastice **44**(1), 22 (2007).
- [9] L. Bejan, A. Sârbu, Optoelectron. Adv. Mater. – Rapid Comm. **2**, 846 (2008).
- [10] <http://msdn.microsoft.com>

\*Corresponding author: lilbejan@yahoo.com,  
lilbejan@tcm.tuiasi.ro