

Deformations analysis of hyperelastic structures using advanced optical systems

L. CIOBANU*, C. DUMITRAS
 „Gheorghe Asachi” Technical University of Iasi, Romania

Knitted fabrics are considered hyperelastic materials due to their high deformation at very low forces. Their mechanical behaviour is atypical and requires extensive theoretical and experimental studies. There are a number of models treating the mechanical behaviour of knitted fabrics, but they are limited in applicability mainly due to structure restriction and simplifying hypothesis. The paper approaches the analysis of tensile deformations of knitted fabrics from a new angle, based on the analysis in real time using advanced optical systems. The paper presents the working method and comments on the results.

(Received July 6, 2010; accepted February 17, 2011)

Keywords: Knitted fabrics, Tensile behaviour, Analysis in real time

1. Introduction

Knitted fabrics are textile structures with complex geometry, different from wovens, that are obtained by successive looping of the yarns (transversally, for weft knitted fabrics), as illustrated in Fig. 1.

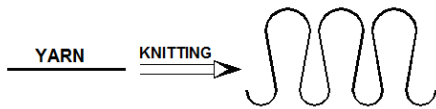

Fig. 1. Knitting principle for weft knitted fabrics

The yarn bending and the interlooping generate a specific geometry. The complex architecture of the knitted

structures creates problems when estimating their mechanical behaviour.

The knitted fabrics, as all textile materials cannot be considered materials with classic behaviour. They are discontinuous and anisotropic materials. Furthermore, due to the particular geometry of the yarn in the knitted stitch, the weft knitted fabrics are characterised by significantly large deformations at very small forces. This is why the knitted fabrics are considered hyperelastic materials. In comparison to woven and non-woven fabrics, they have high elasticity and extensibility, as well as high formability with regard to 3D shapes (bodies).

The modelling of the geometrical and mechanical characteristics of knitted fabrics can be used not only for the direct study of the fabric behaviour, but also for the simulation of the technological processes [4] and for rapid prototyping [2].

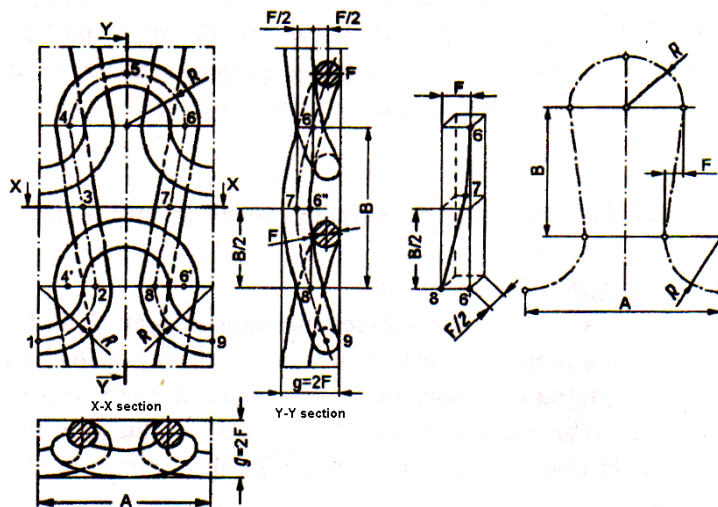

Fig. 2. Dalidovici geometrical model.

The **geometrical models** represent the first attempts to model knitted fabrics. They refer exclusively to the yarn geometry in the knitted stitch. The stitch is considered balanced and the stitch constituent parts have a specific geometric form (segments and circle/ellipse arcs). The yarn cross section is constant (circular, elliptical or lenticular), regardless of the type of yarn used. Due to the specifics, each basic evolution has its own models. Among most mentioned models there are Pierce and Dalidovici models for the jersey evolutions [7, 1]. Fig. 2 exemplifies the Dalidovici geometrical model.

Even if they do not consider the fabric's mechanical behaviour, the geometrical models are used in the **mechanical models**, in order to define the stitch initial geometry (again, mostly Pierce and Dalidovici models).

The mechanical models take into consideration the way the knitted fabrics respond to different types of forces.

Among the most important problems are the identification of forces within the knitted fabrics and the approach to the issue of mechanical behaviour of the fabric. The knitted fabric is made of yarns that are composed of fibres, and therefore the modelling of knitted fabric can be considered at micro level (fibre and yarn) and macro level (fabric). Each level is characterised by the structure and the properties of the fibre/yarn/fabric. The characteristics of the fibre and yarn are transmitted to the fabric and influence its behaviour. Konopasek identified the forces that appear at each level [6]. Fig. 3 expresses the principles of modelling the mechanical behaviour of knitted fabrics.

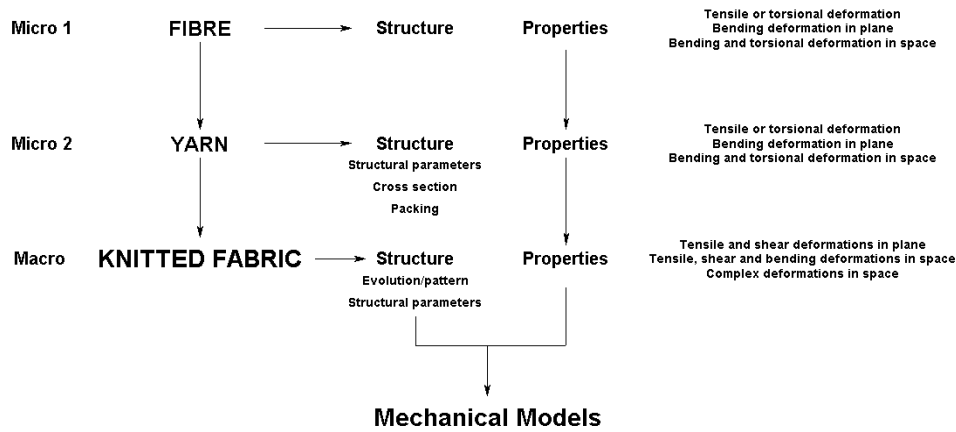

Fig. 3. The approach to modelling the mechanical behaviour of knitted fabrics

There are many attempts to model the mechanical behaviour. Most common approach is the tensile behaviour, while the jersey structure is the one that is most used for modelling mechanical behaviour, due to the fact that it is the most simple and the pattern repeat is of only one stitch.

Generally, the mechanical models can be divided into two groups. One group of models approach the study of mechanical behaviour based on the force analysis, such as Pierce, Konopasek, Hepworth and Leaf, Shanahan and Postle [11], Hepworth, Postle [8] and Postle and Munden [9, 10]. The forces and/or moments are placed at the ends

of these segments. The yarn is considered an elastic rod with properties determined experimentally and the stitch is divided into segments. This hypothesis simplifies the system of non-linear equations to be solved, but restricts the applicability of these models.

For example, the Shanahan and Postle model [11] considers the tensile behaviour of jersey fabrics. The stitch has a specific 3D geometry and the forces and moments are distributed as presented in Figure 4. Hypotheses are made regarding the geometry of the yarn and the directions of the forces/moments. The unit cell is the stitch quarter.

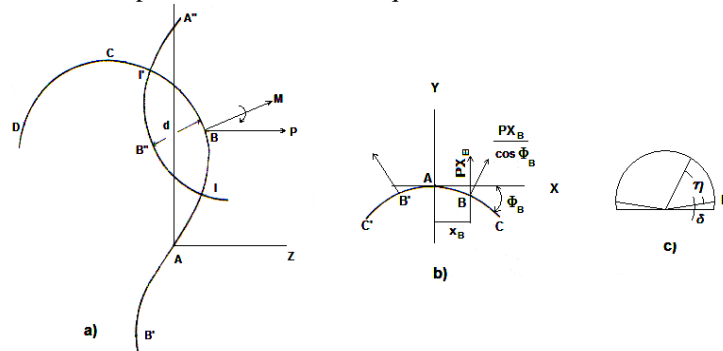

Fig. 4. Shanahan and Postle model

After solving the equilibrium equations for each segment (BCD and B'AB), the potential energy E of the stitch is given by the following equation:

$$\frac{dE}{ds} = \frac{1}{2}B(k_1^2 + k_2^2) - \frac{1}{2}C\tau^2 \quad (1)$$

Where: B = yarn bending rigidity; $C\tau$ = yarn torsional rigidity; k_1 and k_2 = x and y components of yarn curvature
The potential energy e_{AB} for segment AB is:

$$e_{AB} = \int_0^{s_B} \left(\frac{l}{2} - p \cos\theta \right) ds \quad (2)$$

Where: s_B = length of the AB segment; l = constant of integration; $p = P/B$, where P is the force considered acting at the end of the segment; θ = Eulerian angle obtained by rotating the axes about the new Y axis
Segment BC has the energy e_{BC} expressed as:

$$e_{BC} = \frac{1}{2} \left(\frac{l}{R} \right)^2 \times R \left(\frac{\pi}{2} - \varepsilon \right) = \frac{\pi}{2} - \frac{\varepsilon}{2R} \quad (3)$$

Where: R = radius of the BCD segment; ε = interlocking angle for the BC segment

The total energy of the stitch U is:

$$U = eL = 16 \left(\frac{l s_B}{2} - p Z_B + \frac{(\pi - \varepsilon)}{2R} \right) \left[s_B + \left(\frac{\pi - \varepsilon}{2} \right) R \right] \quad (4)$$

Where:

$e = E/B$, where E is the amount of energy stored per yarn unit length; L = loop length; $Z_B = z$ coordinate of point B; l = constant of integration

In a more recent force analysis model, Wu et al [15] replaces the stitch as unit cell with hexagonal elements, with forces acting on each vertex. The mechanical characteristics of the hexagonal cell were defined experimentally and a slippage effect was added in the contact zones in order to improve the model accuracy.

The second group of models consider the deformation of the fabric under forces (de Jong and Postle [3, 4], Hepworth). In an extensive analysis of all mechanical models, Loginov [12] pointed out that these models were restricted by the structure of the fabric – only jersey, the loading conditions and initial hypotheses.

A more accurate model requires the definition of a unit cell that solves the problem of fabric deformation under loading and certain boundary conditions.

Loginov creates a micromechanical model based on FEA, where the fabric is divided into unit cells, made of constituting elements, each with its specific properties [13, 14]. The finite element considered is made of a number of unit cells. The constituting elements of a unit cell are contact zones and yarn segments (three of the considered loop and one of the previous loops).

Loginov replaces the unit cell with rheological models with or without creep flow. The unit cell is divided into three elements, for which he creates models based on energy minimisation: the yarn element, the height element and the helix element. The model proposed by Loginov, Grisahnov and Harwood is presented in Fig. 5.

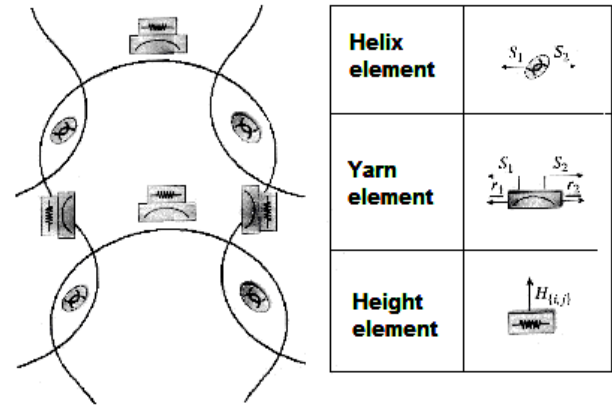

Fig. 5. Unit cell for Loginov model [13]

Regardless of the type of model, the main problems concerning the theoretical mechanical models of the knitted fabrics are:

1. the simplifying hypotheses used with regard to stitch geometry and the forces and/or moments distribution
2. the complex mathematical apparatus, at different levels, that requires its own hypotheses for each level
3. the restriction of most models to only one structure (mostly jersey that has the simplest geometry), other knitted structures being considered too complex to model.

2. Analysis in real time of knitted fabrics' strain

The analysis in real time of the mechanical behaviour of knitted fabrics can be used as the base for modelling their deformation. The analysis in real time represents a new approach for knitted fabrics.

The most important aspect is the fact that the analysis allows studying the real behaviour of fabrics during the strain, thus eliminating the restrictive simplifying hypotheses used for theoretical models based on forces or deformations analysis.

The mathematical models based on forces analysis consider the stitch only in distinct moments. The dynamic modelling in real time shows the deformations in all stages, according to the real dimensional modifications in the stitch and yarn geometry.

Another significant advantage is given by the fact that there are no structural restrictions – all types of structures can be considered, regardless of their complexity. Furthermore, all types of mechanical strains can be analysed.

The second novelty aspect is the fact that such an analysis takes into consideration all aspects regarding the mechanical forces to which a fabric is subjected.

The information concerning knitted fabric deformations was obtained using an advanced system for 3D optical analysis, produced by GOM. Both systems developed by the company were tried. The tests and data interpretation were conducted with the help of Spectromas company, Bucharest.

2.1. Experimental Matrix

The samples considered for testing were made of two types of yarns – an acrylic classic yarn, count Nm 28/2/3 and a PES high tenacity yarn, count 2x1100 dtex. The following basic evolutions were considered for testing: jersey, 1x1 rib and 1x1 purl. Their aspect and representations are illustrated in Fig. 6.

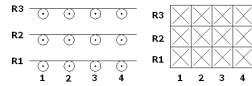

Jersey fabric – real aspect (front), knitting sequence and symbolic representation

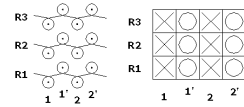
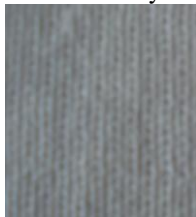

Rib 1x1 fabric – real aspect (front), knitting sequence and symbolic representation

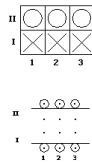
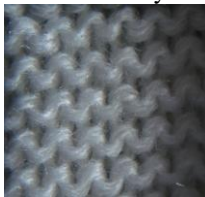

Purl 1x1 fabric – real aspect (front), knitting sequence and symbolic representation

Fig. 6. Aspect and representation of the tested fabrics

The fabrics were produced on a flat knitting machine, CMS 330TC (Stoll), gauge 5E. The technological parameters (quality stitch cam position, yarn tension and fabric take-down speed) were selected within the normal intervals, in order to obtain quality fabrics with average stitch density.

2.2. 3D Optical Analysis System

The use of optical analysis of deformations is well documented in the case of classic materials (such as metals, characterised by small deformations at high forces). There are some recent references [16] regarding the use of Aramis system to study the behaviour of

composite materials reinforced with textiles, including carbon wovens. This type of materials has behaviour similar to the classic materials. As knitted fabrics present a different behaviour, the use of such systems to analyse their deformations represents a solution with high potential for development.

Initially, the **Aramis system** was considered for the study, due to the fact that it gives the best information at surface level. According to the standard working methodology, two types of paint were spread on the samples' surface. Two types of problems were encountered. For all samples the special paint was absorbed by the yarns, making any analysis impossible.

2.3. Working Method

Because of the problems encountered with the Aramis system, it was considered the optical analysis of fabric deformations through points, using the **Pontos system** [17]. The system follows the displacement during the strain of special markers placed on the samples (see Figure 7). The markers were placed on each sample in a matrix shape (3 rows and 7 columns). The samples were tested for tensile strain on a Lloyd machine. The entire experimental system is illustrated in Figure 8 (image acquiring equipment, Pontos system and testing machine).

The data acquirement was conducted under the following conditions:

- Tensile testing machine – width of gripping system – 25 mm; distance between jaws – 100 mm; test speed – 25 mm/min
- Image acquiring system – frame speed = 1 frame / second
-



Fig. 7. Markers matrix on samples.



Fig. 8. Experimental equipment

The fabric samples were tested in both directions (horizontal/rows and vertical/wales). The deformation was determined based on a number of three points, considered on three distinct levels, as illustrated in Figure 9. Figure 10 presents the displacement path for the chosen points during the strain.

The three initial points determine an angle ϕ , its variation giving information about the fabric deformation (see Figure 11). The ϕ angle defines the compression on the direction perpendicular to the test direction and it is used to determine the dimensional modifications of the samples during the test. The deformations can be also obtained from the displacement of the initial points in reference to a virtual median line.

Fig. 12 presents the displacement measurement for the considered points along the three axis and the corresponding deformations in the XY plan.

The data acquired during the test can be used to define and interpret the different phases of the fabric's strain.

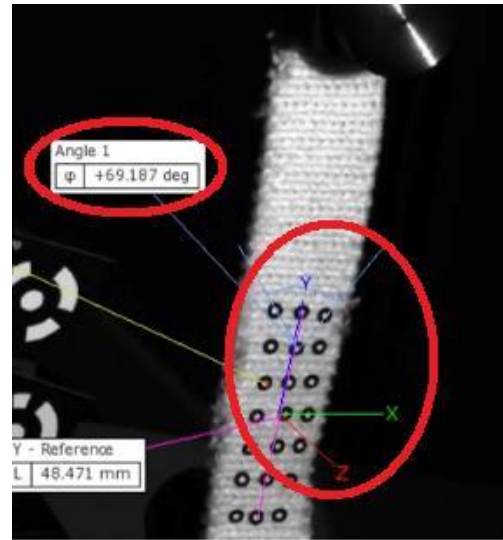

Fig. 11. Definition of the initial angle.

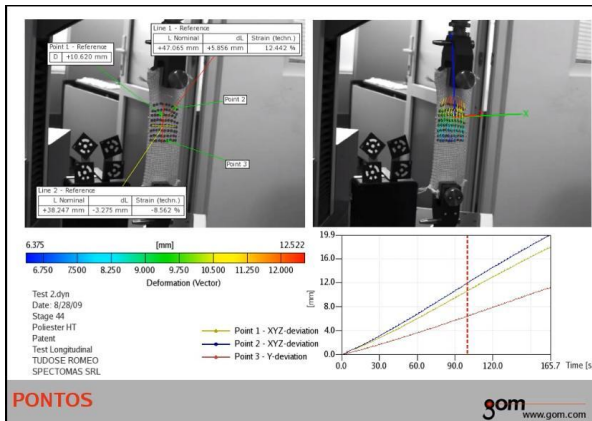

Fig. 9. Data regarding the deformations in three separate points

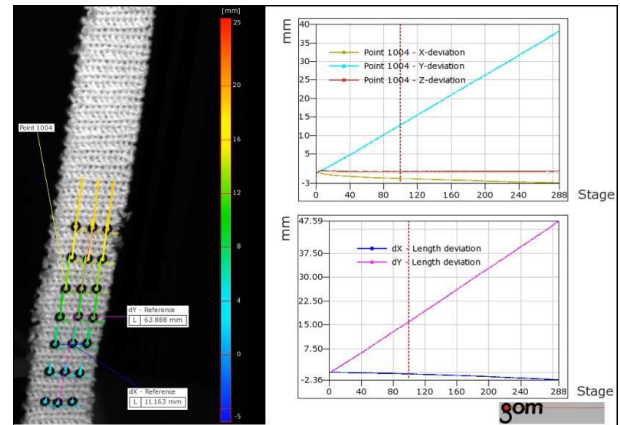

Fig. 12. Displacement of a point considered at a moment t , along the xyz axis and the deformations considered in the xy plan.

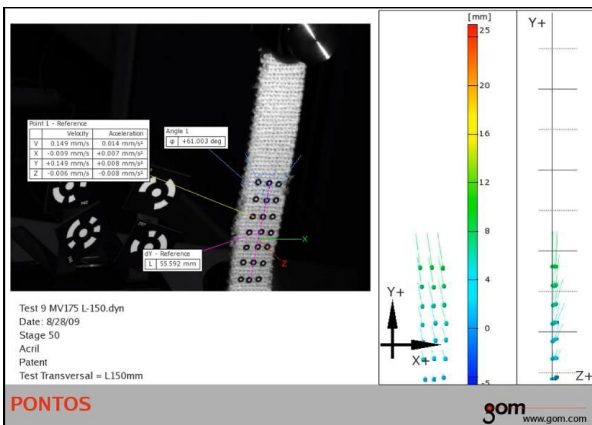

Fig. 10. Displacement directions for the considered points.

3. Results and discussions

The data acquired during the tests is ample, offering an wide range of information and allowing for analysis from different points of view. Furthermore, the information gives the resultant deformation in real time, as well as the deformations along the XY axes. Table I exemplifies this data, considering the different fabrics made of acrylic yarns and the test direction (for jersey). For reasons related to space, the time increment used for this Table is 20 seconds, even if all graphical interpretation takes into consideration a 10 seconds increment.

Table 1. Deformations along the axis with time, for different types of knitted fabrics and test direction.

Time (sec)	Jersey Transv		Jersey Longit		Rib Transv		Purl Transv	
	dX [mm]	dY [mm]	dX [mm]	dY [mm]	dX [mm]	dY [mm]	dX	dY
0	0	0	0	0	0	0	0	0
20	-0.724	5.416	-0.884	2.946	-0.101	4.96	-0.31	3.915
40	-1.545	10.975	-1.515	6.34	-0.258	9.63	-0.749	8.616
60	-2.314	16.426	-2.126	9.5	-0.46	14.257	-1.236	13.523
80	-3.08	21.726	-2.65	12.387	-0.669	19.242	-1.899	17.84
100	-3.732	26.669	-3.177	15.257	-0.98	24.206	-2.648	22.516
120	-4.333	31.42	-3.667	18.082	-1.23	29.193	-3.142	27.227
140		35.554	-4.045	20.208	-1.584	34.192	-3.77	31.919
160		38.911	-4.333	22.04	-1.946	39.238	-4.625	36.202
180		41.589	-4.496	23.386	-2.332	44.121		40.054
200		43.67	-4.623	24.151	-2.702	48.975		
220		45.106	-4.702	24.933	-3.075	53.866		
240		46.044	-4.673	24.988	-3.463	58.671		
260					-3.922	63.472		
280					-4.528	68.159		

The data presented in Table I show the real differences between the tensile behaviour along the two axes (for the acrylic jersey fabrics). It also emphasises the compression along the perpendicular direction, and subsequent jamming phenomenon, appearing more quickly for the jersey fabrics, then purl and finally rib fabric.

The experimental model allows the comparison between different structures, comparison impossible for theoretical models.

An interesting aspect of the present study is the comparison between the behaviour of jersey and purl fabrics, the latter characterised by jersey rows of different aspect.

4. Discussions

The optical analysis of the fabric deformations in real time and during the entire test period allows the following observations.

1. The different stages of the tensile strain are clearly put into evidence in reference to the deformation of yarns (this process being modelled theoretically).

The identified stages emphasise the deformations in stitch geometry and dimensions, followed by the yarn deformation and subsequent fabric breaking.

Knitted fabrics with basic evolutions can be divided into two groups:

- Fabrics where the stitches are placed in a single plan – it is the case of jersey fabrics.
- Fabrics with stitches placed in two separate plans (front and rear) – rib fabrics (the front and rear stitches are superposed along the row direction, at sinker loops level) and purl fabrics (the stitch superposing is along the wale direction, at stitch arms level).

According to the specific geometry of each evolution, the stages before yarn deformation are:

Modification of stitch relative position (elimination of front and rear stitch superposing for the fabrics made on two beds) without any dimensional change. This stage appears only for rib and purl fabrics.

Modification of stitch dimensions through yarn migration and its redistribution according to the strain direction. From this point of view, the strain direction is very important. In the case of transversal strain, the redistributed yarn amount comes from the stitch arms and is higher than in the case of longitudinal strain, where the amount comes from the loops toward the arms, therefore is much smaller. This situation will influence the duration of this stage.

The amount and duration of the yarn migration is also conditioned by the yarn-yarn friction coefficient in the contact areas. A classic yarn such as acrylic has a higher friction coefficient, while technical yarns such as PES HT or glass have lower values.

At a certain moment, the migration stops and the **jamming** appear. All yarns come into direct contact with each other and start to be compressed. The friction forces are so high that no relative displacement is longer possible. The deformation transfers from the stitch level to the yarn level, until yarn breaking.

These stages of yarn migration and redistribution within the stitch correspond to very small forces. An important aspect shown by the optical analysis is the fact that these processes do not take place in the same moment for all stitches from the fabric sample.

2. From the study of the experimental data according to all process stages, it can be affirmed that the deformations are constant along the force direction and do not have a constant rate. Therefore, there will be critical zones where the breaking can occur earlier.

3. The friction forces in the contact areas prove to be essential for the definition of mechanical models.

4. The deformation process is taking place on two perpendicular directions – the force direction and the fabric thickness. Along the thickness direction, there is a

lesser compression, with lower rate, that ends when the jamming appears.

5. The tensile behaviour of the knitted fabrics was similar for all types of fabrics and raw materials. This leads to the elimination of the restrictions regarding the structure existing in the theoretical models.

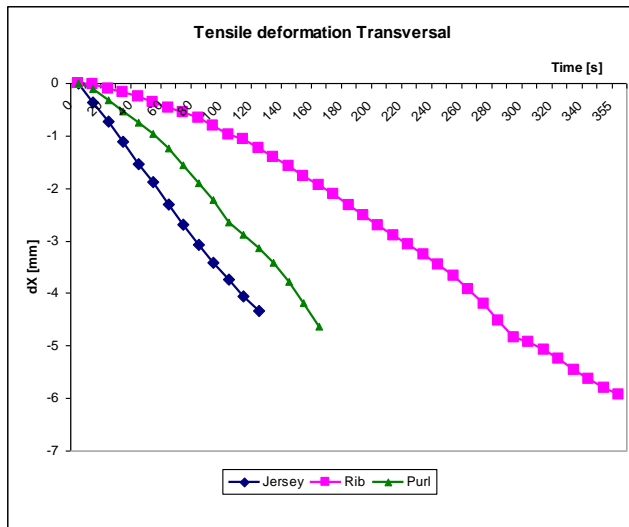

Fig. 13. Transversal tensile deformation - perpendicular to the loading direction.

The graphics presented in Figure 13 and Figure 14 show the deformations along both axes with time for the transversal test results. The graphics emphasise the compression along the X axis (perpendicular to testing direction) and extension along the Y axis.

When comparing the deformation according to structure, the influence of the specific geometry is clear. For the jersey fabric, with the stitches placed in a single plan, the compression on the axis perpendicular to the loading direction is the smallest in value and also it takes place in the shortest amount of time. It indicates that the jamming phenomenon occurs in the shortest period.

The compression of the purl sample is similar to the jersey one, but the contraction rate decreases slightly with time, therefore the sample reaches the jamming stage later. There is a small increase of the deformation (around 7%) that can be justified by the specific position of the purl stitches (superposed at stitch arm level).

The rib fabric exhibits the highest compression for transversal tensile loading. The compression rate is lower, indicating that a significant amount of yarn is migrating. The duration of the migration stage is double when compared to the other structures, while the actual value of deformation is with 35% higher than the compression of the jersey fabric.

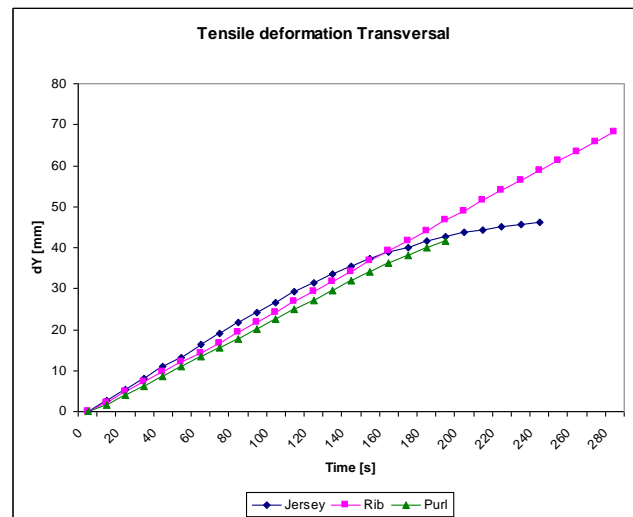

Fig. 14. Transversal tensile deformation - along the loading direction.

The sample deformation recorded along the loading axis (dY) is positive (elongation) and significantly higher for all structures (see Fig. 14). The rib shows the highest deformation, while the jersey and the purl fabrics have similar values.

Again, there is a difference in the elongation rate for the three structures. This time the purl fabric presents the lower deformation rate, suggesting that the stitch superposing limits to a certain point the fabric elongation. Furthermore, the jersey fabric presents an elongation around 13% higher than the one recorded for purl fabric.

The elongation rate for the jersey fabric decreases toward the end of the second half of the test period until the deformation is no longer significant (indicating the fabric already reaches the jamming stage and the deformation is transferred to yarn level).

The rib fabrics present the highest elongation (as expected). The elongation increases linearly. The yarn migration period is longer for the rib stitches, due to their specific geometry (stitches placed in two plans, a higher amount of yarn able to migrate).

Another interesting aspect is the influence of the test direction (Transversal and Longitudinal). Even if the deformation is different, due to the different amount of yarn involved in the migration stage, the graphic in Figure 15 shows that the compression perpendicular to the test direction is similar with regard to its value (dX_T and dX_L), while the time required for compression is double for longitudinal loading. For longitudinal loading, the most significant influence factor of the migration stage is the friction coefficient.

The elongation (dY) for transversal direction is double when compared to the longitudinal direction. The graphics emphasise that the influence of the difference in the amount of yarn that migrates within the stitches is stronger for this test direction.

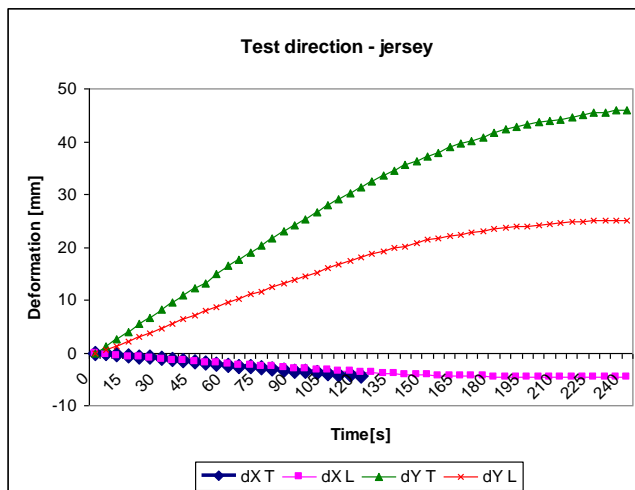

Fig. 15. Fabric deformation according to test direction – jersey fabric

4. Conclusions

Mechanical behaviour of knitted fabrics represents a difficult subject due to their specific geometry, their anisotropy and their hyperelasticity. There are two types of models concerning this behaviour – based on forces/moments analysis and analysis of deformations. All theoretical mechanical models refer to a single type of structure (jersey for almost all models), a type of raw material and a type of strain. Also, these models use restrictive initial hypotheses in order to solve the complex systems of equations.

Optical analysis of fabric deformations in real time represents an alternative to these models. It offers a set of advantages given by the fact that there are no more restrictions. It is also a dynamic analysis and therefore the stitch and yarn deformations are continuously monitored. The volume of information resulting is huge and allows the comparison between the behaviour of different types of fabrics.

The paper presents the results obtained with the analysis of deformations using a GOM system. Optical analysis of fabric deformations in real time is possible, but the specific geometry of knitted fabrics is more adapted to an analysis through points (Pontos system) and not at surface level (Aramis system). The knitted fabrics were subjected to tensile forces and all types of basic evolutions (jersey, rib and purl) were considered for testing.

The analysis allows following all stages of the deformation process according to structural specifics, to identify the directions of deformations and to compare the results. It can also be used to determine the duration of each stage in time until jamming. The analysis offers significant information regarding the rate of deformation.

Such data is useful in determining a theoretical model where the stage of yarn migration and subsequent jamming is accurately described, according to fabric structure.

Further work will concern other types of strain, as well as other more complex types of knitted structures.

Acknowledgements

The present paper is published within the frame of research project PN II ID no. 376/2007, funded by the Romanian Government through CNCISIS.

The authors wish to thank Spectromas Company, sales representative for GOM, for their help.

Reference

- [1] A.S. Dalidovich, *The Basic Theory of Knitting*, Legkaya Industria, Moskow (1970)
- [2] G. A. Bingham, R. J. M. Hague, C. J. Tuck, A. C. Long, J. J. Crookston, M. N. Sherburn, *International Journal of Computer Integrated Manufacturing*, **20**, 96, (2007)
- [3] S. De Jong, R. Postle, *J. Text. Inst.*, **68**, 307 (1977)
- [4] S. De Jong, R. Postle, *J. Text. Inst.*, **68**, 316 (1977)
- [5] A. Klar, N. Marheineke, R. Wegener, *ZAMM · Z. Angew.Math. Mech.* **89**, 941 (2009)
- [6] M. Konopasek, *Classical Elastica Theory and its Applications*, in *Mechanics of Flexible Fibre Assemblies*, editor JWS Hearle, JJ Thwaites, and J. Amirbayat, Sijthoff&Noordhoff (1970)
- [7] F.T. Pierce, *Text Res J.*, **17**, 123 (1947)
- [8] R. Postle, *Journal of the Textile Institute* **92**(3), 80 (2001)
- [9] R. Postle, D.L. Munden, *Text. Res. J.*, **58**, 329, (1967)
- [10] R. Postle, D.L. Munden, *Text. Res. J.*, **58**, 352, (1967)
- [11] W.J. Shanahan, R. Postle, *Text. Res. J.*, **67**, 656 (1970)
- [12] A.U. Loginov, S.A. Grishanov, R.J Harwood, *J. Text. Inst.*, **93**, part 1, 3, 218 (2002)
- [13] A.U. Loginov, S.A. Grishanov, R.J Harwood, *J. Text. Inst.*, **93**, part 1, 3, 239 (2002).
- [14] A.U. Loginov, S.A. Grishanov, R.J Harwood, *J. Text. Inst.*, **93**, part 1, 3, 251 (2002)
- [15] W.L. Wu, H. Hamada, Z. Maekawa, *J. Text. Inst.*, **85**(2), 198 (1994)
- [16] <http://www.youtube.com/watch?v=I3VrllZTTRA>
- [17] <http://www.gom.com/metrology-systems/3d-motion-analysis.html>

*Corresponding author: lciobanu@tex.tuiasi.ro