

Research on high illumination uniformity underwater optical system design

Y. WANG, Y. C. ZHANG*, D. PAN, X. F. XIE, C. C. SUN

School of Information Science & Engineering, Dalian Polytechnic University, Dalian, Liaoning, China

In the underwater attenuation environment, it is hard to achieve high uniformity in a long illumination range for the optical designed based on a certain illumination distance. This paper proposes an optical design method of multi-regional illumination in seawater, which makes the different areas be illuminated with different luminous fluxes at different distances to expand the distance range of uniform illumination. In the lighting design example of this paper, this paper realizes high illumination uniformity lighting from 1 to 10 meters. The illumination uniformity is defined as the ratio of the minimum illuminance value to the average illuminance value. Compared with the traditional design method, the illumination uniformity of this method in the lighting distance exceeds 0.7, while the minimum illumination uniformity is less than 0.4 in the traditional illumination system.

Received November 6, 2022; accepted October 6, 2023)

Keywords: Optical design, Illumination uniformity, Underwater light attenuation

1. Introduction

With the development of seawater resource survey, seawater mineral exploitation and seawater in-situ biological and chemical activity observation, seawater operations such as manned submersibles, underwater robots and landers need high-quality lighting effects[1-2]. It is significant to improve the transmission distance of light and illumination uniformity in the seawater, which can be applied to high-quality lighting applications such as deep-sea exploration [3].

Influenced by the temperature and salinity of seawater, suspended particles and dissolved substances in seawater, the nonlinear attenuation of monochromatic light in the seawater is an important reason why it is difficult to achieve high-quality illumination in the seawater illumination optical system at present [4]. The nonlinear attenuation problem in seawater is analyzed from multiple perspectives. A theoretical analysis method is introduced for analyzing the light attenuation of seawater in seawater with different water quality and different sea areas [5]. Through the analysis of the correlated attenuation probability and average

signal-to-noise ratio of horizontally propagating plane waves and spherical waves, theoretical results indicate that the receiver aperture and waveform can effectively influence the performance of optical system [6-7]. Although the non-multi-regional design scheme has analyzed the nonlinear attenuation problem in seawater to a certain extent, it has not fundamentally solved the problems of large light attenuation and uneven illumination in seawater lighting, and has not analyzed the difference and improvement of spatial light intensity distribution at different distances.

The optical system design of LED light source plays an important role in solving the problem of light transmission in seawater. The advantages and disadvantages of parabolic, ellipsoid and spherical light distribution elements in seawater lighting systems are analyzed and the effects of glossy, frosted glass and diffuse reflection on light uniformity can also not be ignored [8]. The study found that a smaller launch angle is required to obtain a longer transmission distance [9]. The LED multi-segment free-form lens is chosen for fishing lights design, which can provide full design freedom compared to continuous free-form surfaces [10].

This design aims at improving the illumination uniformity of light in the seawater, and solving the problems of nonlinear attenuation of various monochromatic lights by means of modular optical system design. This system can realize multi-regional lighting and the modulation of the luminous flux of light sources at different transmission distances, which can achieve high-uniformity lighting in a larger space.

2. Analysis of light attenuation characteristics of the LED light source in seawater

The attenuation characteristics of light in seawater are determined by the absorption and scattering of water molecules and suspended matter. In the seawater, the spatial intensity of the light emitted by the light source will decay with distance, unlike when the attenuation in the air can be neglected [11-13]. Assuming that the LED light source is Lambert light source, the initial light intensity I in the direction of θ and the initial light intensity I_0 in the central direction satisfy the formula 1.

$$I = I_0 \cos \theta \tag{1}$$

The transmission characteristics of the emergent light of the LED light source in the seawater satisfy formula 2:

$$I' = I \cdot e^{-\mu L} \tag{2}$$

in which, μ represents the attenuation coefficient of light with different wavelengths in seawater, and L represents the transmission distance of light.

Due to the influence of salinity, impurities and other factors in seawater in different sea areas, the effects on light attenuation are also different. This paper focuses on analyzing the spatial attenuation of light intensity in the seawater due to the existence of light attenuation. Therefore, this paper takes the middle ocean water as an example to analyze several typical wavelengths of outgoing light. The light attenuation coefficients of different wavelengths of outgoing light in the seawater are shown in Table 1 below.

Table 1. Attenuation coefficient of light with different wavelengths in seawater

wavelength /(nm)	400	425	450	475	500	525	532
attenuation coefficient /(dB/km)	0.202	0.139	0.097	0.083	0.080	0.089	0.090
wavelength /(nm)	550	575	600	625	650	675	700
attenuation coefficient /(dB/km)	0.097	0.146	0.264	0.299	0.351	0.466	0.594

It can be seen from Table 1 that the attenuation coefficients of different wavelengths of light in seawater are different. The attenuation coefficient of middle band is the smallest, followed by blue-violet band, and the attenuation coefficient of red-orange band is the largest. In the seawater, monochromatic wavelengths with high transmittance are usually selected. This paper studies monochromatic wavelengths, analyzes the spatial transmission characteristics of monochromatic wavelengths and the corresponding optical design

methods.

Assuming that the LED light source is Lambert light source, according to formulas 1 and 2, the relationship between the light intensity I' with the exit angle θ and the initial light intensity I_0 is shown in formula 3.

$$I' = I_0 \cdot \cos \theta \cdot e^{-\frac{\mu L_0}{\cos \theta}} \tag{3}$$

where L_0 represents the center transmission distance. If a uniform illumination distribution is formed on the target plane, its illumination satisfies the law of inverse square distance, as shown in Equation 4.

$$E = \frac{I \cdot \cos \theta}{L^2} \tag{4}$$

Combined with formulae 3 and 4, the relationship between light intensity I and luminous angle θ can be obtained as follow.

$$I = \frac{E \cdot L_0^2}{e^{-\frac{\mu L_0}{\cos \theta}} \cdot \cos^2 \theta} \tag{5}$$

where E is the illumination of the target surface, and θ is the exit angle of the light. L is defined as the luminance.

According to formula 5, it can be seen that light intensity distribution is affected by the light attenuation of the seawater.

In order to analyze the influence of seawater light attenuation on the light intensity distribution, we take monochromatic light with a wavelength of 500nm as an example, and the attenuation coefficient of light transmitted in seawater is 0.080dB/km. It is assumed that uniform illumination is achieved at different positions with a minimum distance of 1m, an intermediate distance of 5m, and a maximum distance of 10m to test the influence of different degrees of deep-sea light attenuation on the lighting effect. The spatial distribution of the light intensity emitted by the light source is shown in Fig. 1.

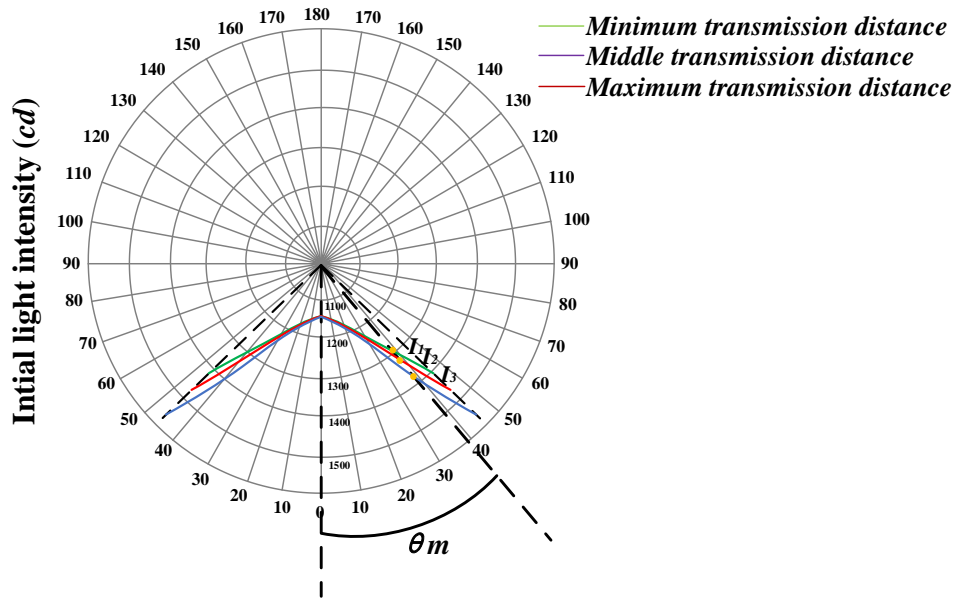

Fig. 1. Light distribution curves at different transmission distances (color online)

It can be found from the figure that in order to realize uniform illumination at different distances, the spatial light intensity distribution requirements of the light emitted by the light source are completely different. It can also be considered that the spatial photometric distribution of a light source can only achieve uniform illumination at a specific distance, and cannot achieve uniform illumination at a long distance at the same time.

The illumination range of the optical system can be divided into a central illumination area, and an annular illumination area is adopted outside the central

illumination area and accumulated with it. In this way, the lighting method in which the space is divided into multiple areas is beneficial to adjust the illuminance of different areas, and uniform lighting can be achieved in the enlarged space.

3. Design of high uniformity seawater illumination optical system

In this paper, the space is divided into several annular areas for lighting. The inner area is illuminated

by a light source controlled by the central lens, and the outer ring area is illuminated by a light source passing through the ring lens. Each area can achieve high uniformity illumination with different transmission distances by adjusting the luminous flux of the light source.

Taking medium seawater as an example, the deep-sea light attenuation analysis is carried out, and it is

proposed that the difference in light attenuation of deep-sea light under different illumination angles is the root cause of the difficulty in achieving high-quality lighting in the deep-sea. The central lens and the annular lens are designed respectively, and finally a lens array is formed. By adjusting the luminous flux ratio of each lens of the deep-sea lighting module, uniform illumination can be achieved at each transmission distance.

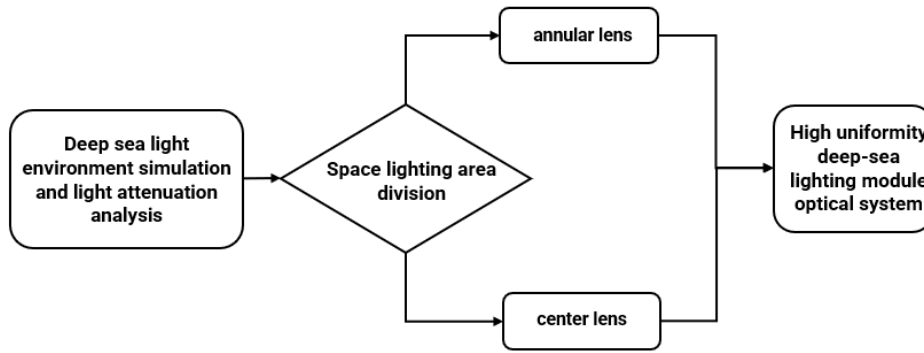

Fig. 2. Flow chart of optical system design

3.1. Central lens design

After determining the illumination distance range and light intensity variation coefficient requirements, the illumination range of the central area and the annular area can be determined by the above method. Then the

key issues of the optical system is how to achieve the illumination uniformity of the two illumination areas. In this paper, the internal total reflection free-form surface lens is used to realize the uniform illumination lens design in the central area. The structure of the Central lens is shown in Fig. 3.

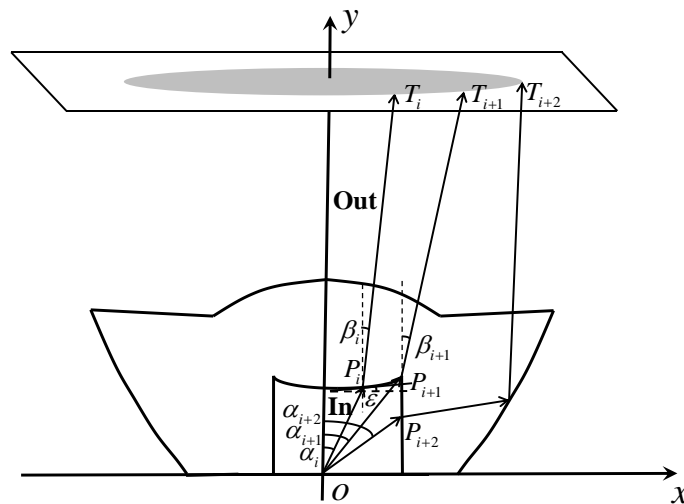

Fig. 3. Mathematical modeling diagram of central lens

Because the total luminous flux of LED light source and the total luminous flux of central lens satisfy the law of energy conservation. Therefore, there are formulas (6), (7) and (8):

$$\Phi_s = \sum 2\pi I_{s_i} (\cos\alpha_i - \cos\alpha_{i+1}) \quad (6)$$

$$\Phi_L = \sum 2\pi I_{L_i} (\cos\beta_i - \cos\beta_{i+1}) \quad (7)$$

$$\Phi_s = \Phi_L \quad (8)$$

in which Φ_s is the total luminous flux of the LED light source, Φ_L is the total luminous flux of the central lens, α and β are the angles between two adjacent emergent rays of the light source and the vertical direction respectively.

Assuming that the LED light source is a point light source with the origin of coordinates O , it is known that the coordinates of the center point P_0 of the outer surface of the lens are (x_0, y_0) . The exit angles of the two rays emitted from point O are α_i and α_{i+1} , respectively, and the incident points of the free-form surface reaching the central lens are P_i and P_{i+1} . The tangent slope of free-form surface at any point is k_i , and its expression is formula 9.

$$k_i = \frac{y_{i+1} - y_i}{x_{i+1} - x_i} \quad (9)$$

The angle between the tangent of any point on the free-form surface of the central lens and the horizontal direction is ε_{i+1} . The emergent light of the LED light source is refracted by the free-form surface of the central lens and irradiated into seawater, which satisfies the refraction relation shown in formula 10.

$$n_1 \cdot \sin(\alpha_i + \varepsilon_i) = n_2 \cdot \sin(\beta_i + \varepsilon_i) \quad (10)$$

in which n_1 is the refractive index of PMMA and n_2 is

the refractive index of seawater.

According to formula 10, another expression of the tangent slope of free-form surface at any point is k_i , as shown in formula 11.

$$k_i = \frac{n_1 \cdot \sin \alpha_i - n_2 \cdot \sin \beta_i}{n_2 \cdot \cos \beta_i - n_1 \cdot \cos \alpha_i} \quad (11)$$

According to formula 11, the tangent slope of free-form surface at any point is k_i , and because of $\tan \alpha_i = \frac{y_i}{x_i}$, the coordinates of each sampling point on

free-form surface can be obtained by combining formula 9, as shown in formulas 12 and 13.

$$x_{i+1} = \frac{(y_i - k_i x_i) \tan \alpha_{i+1}}{(1 - k_i \tan \alpha_{i+1})} \quad (12)$$

$$y_{i+1} = \frac{y_i - k_i x_i}{1 - k_i \tan \alpha_{i+1}} \quad (13)$$

Using the coordinates of all sampling points on the free-form surface, the generatrix of the free-form surface is constructed. The generatrix of the free-form surface is rotated once to form the free-form surface, and then the central lens is constructed.

3.2. Annular lens design

The annular lens is used to achieve a uniform annular illumination spot in seawater [14]. Fig. 4 is the mathematical modeling diagram of the lens. The lens consists of three parts: inner surface, TIR and outer surface. The inner surface refracts light rays in the central portion to form collimated rays. The high-angle light of the light source reflected by the lens into collimated light.

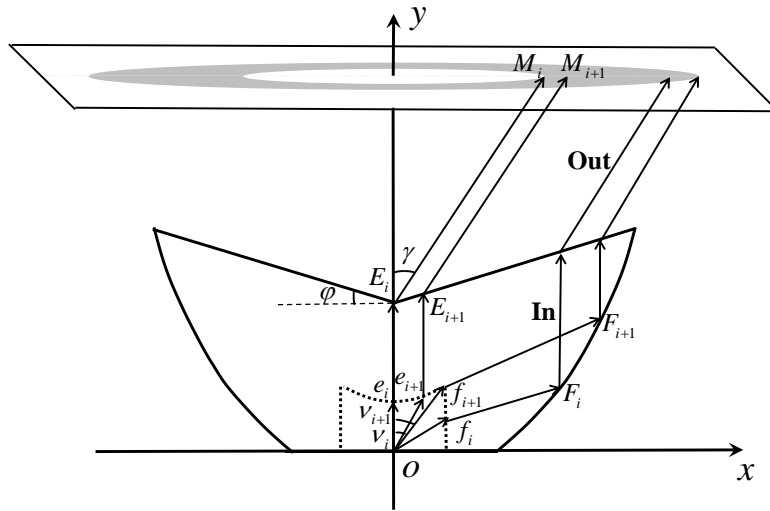

Fig. 4. Mathematical modeling diagram of annular lens

Mathematical modeling is carried out on the inner surface, so that the light emitted by the LED light source passes through the inner surface to form collimated light. Let's assume that the LED light source is a point light source with the origin of coordinates O , the outgoing angles from point O are v_i, v_{i+1} rays respectively, and the point coordinates of the incident rays reaching the inner surface of the annular lens are $e_i(x_i, y_i)$ and $e_{i+1}(x_{i+1}, y_{i+1})$. The light passing through the inner surface follows the vector form of the law of refraction, as shown in formula 14.

$$n_{in} \sin v_{in} = n_{out} \sin v_{out} \quad (14)$$

where n_{in} is the refractive index of the medium in which the incident ray is located, n_{out} is the refractive index of the medium in which the outgoing ray is located, v_{in} is the incident angle and v_{out} is the refraction angle.

According to formula 14, the iterative relationship of coordinates between two adjacent sampling points can be obtained as shown in formulas 15 and 16, and then the

coordinates of each sampling point on the inner surface can be obtained.

$$y_{i+1} = \frac{k_i x_i - y_i}{[k_i \tan(v_{i+1}) - 1]} \quad (15)$$

$$x_{i+1} = \frac{k_i x_i - y_i}{[k_i \tan(v_{i+1}) - 1]} \tan(v_{i+1}) \quad (16)$$

in which $k_i = \frac{y_{i+1} - y_i}{x_{i+1} - x_i}$ is the tangent slope of point e_{i+1}

on the free-form surface, and $\tan v_{i+1} = \frac{y_{i+1}}{x_{i+1}}$ is the

tangent value of the emergent angle v_{i+1} corresponding

to ray Oe_{i+1} .

By using the iterative relationship between two adjacent points, all sampling points on the inner surface are obtained, and the generatrix of the inner surface is rotated once to form the inner surface. The light is blended by the slope angle γ of the outer surface to form continuous annular illumination spots on the target plane.

4. Optical system design and analysis

In order to achieve a high-uniformity underwater lighting effect, the optical system of the lighting module is used for underwater lighting. The optical system of the illumination module includes two kinds of lenses, one is the central lens that produces the middle circular illumination spot, and the other is the annular lens that

produces a certain number of annular illumination spots. By adjusting the luminous flux ratio between lenses (generating the luminous flux of light sources corresponding to different illumination areas), high uniformity illumination can be achieved in the illumination range of different distances. The structural diagram of the optical system is shown in Fig. 5.

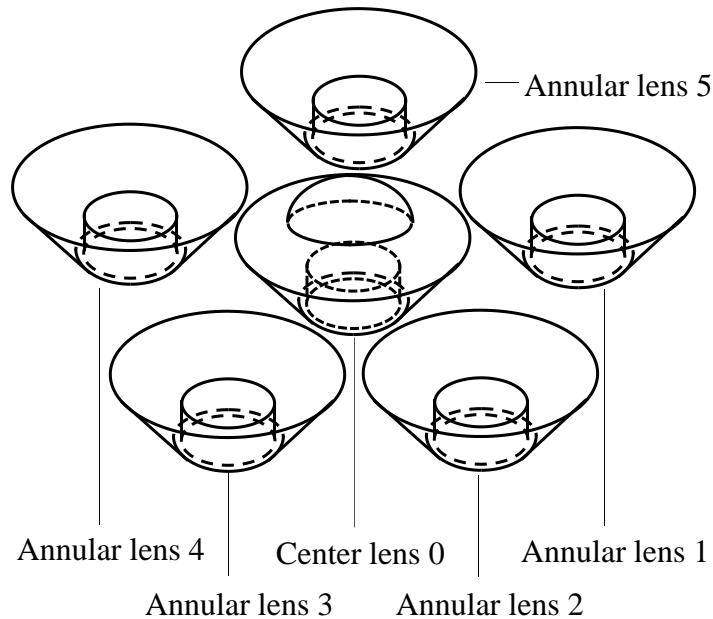

Fig. 5. Optical system structure diagram of seawater lighting module with high uniformity

In the high-uniformity seawater illumination module optical system shown in Fig. 8, each lens controls a different light-emitting angle. The optical system of the seawater lighting module with high uniformity is suitable for the transmission distance from 1m to 10m. When the illumination range is between 20° and 30° , five annular

lenses are used, and the luminous flux of the LED light sources is adjusted to meet the requirements of high-uniformity illumination for different illumination distances. The model diagrams of the center lens and the annular lens are shown in Fig. 6.

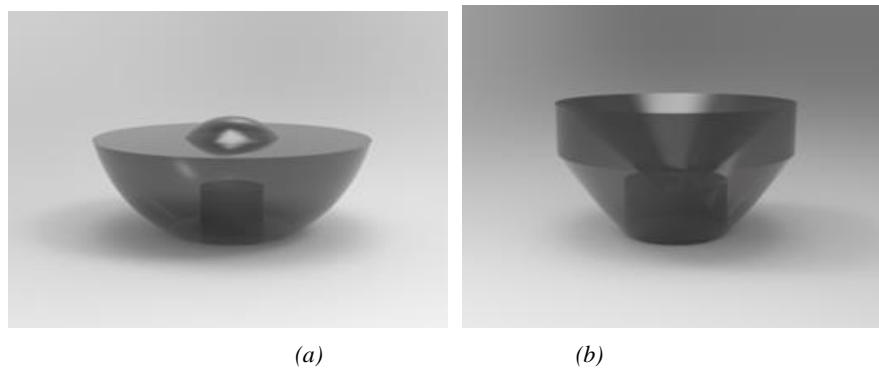

Fig. 6. Model diagram of (a) central lens and (b) annular lens

The illumination angle range of each lens and the luminous flux setting of the corresponding LED light source given in the design example are shown in Table 2.

Table 2. Illumination angles of different lenses

performance	Illumination range	Light source luminous flux
Center lens 0	0° - 20°	Φ_0
Annular lens 1	20° - 22°	Φ_1
Annular lens 2	22° - 24°	Φ_2
Annular lens 3	24° - 26°	Φ_3
Annular lens 4	26° - 28°	Φ_4
Annular lens 5	28° - 30°	Φ_5

In this design, a typical seawater is selected for analysis, and its attenuation coefficient is 0.080dB/km. The LED light source used in this paper is OSLO LV CQBP-JZLX-BD-1, with the size of 3mm×3mm and monochromatic light with wavelength of 505nm. In the design, the central lens is made of PMMA with a refractive index of 1.49, and the annular lens is made of flint glass with a refractive index of 1.88. Using the above lens design method, the lens model diagram is obtained through calculation and modeling as shown in Fig. 7.

In order to achieve high uniformity illumination at different distances, it is necessary to adjust the luminous flux of the light source according to the illumination distance. When the illumination distance is 5m, the luminous flux ratio of five groups of light sources is 151: 52: 59: 68: 76: 85. Set the luminous flux of the light source at this ratio, and the obtained ray tracing effect is shown in Fig. 8.



Fig. 7. Simulation model diagram of optical system (color online)

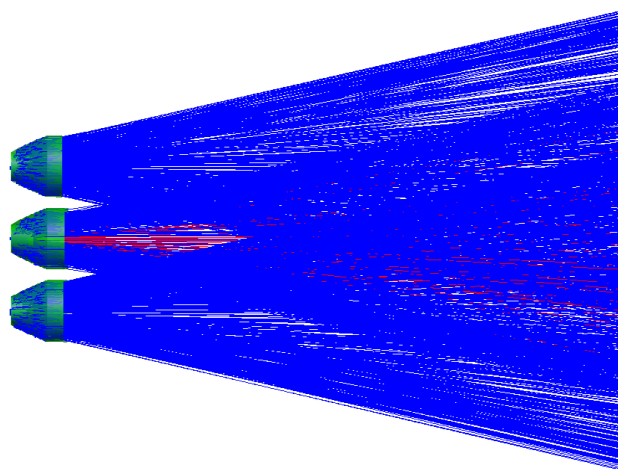

Fig. 8. Ray tracing diagram of lighting module (color online)

The optical system includes six groups of lenses and corresponding light sources. The obtained illuminance diagram of these six groups of light sources and lenses at a distance of 5m from the system is shown in Fig. 9.

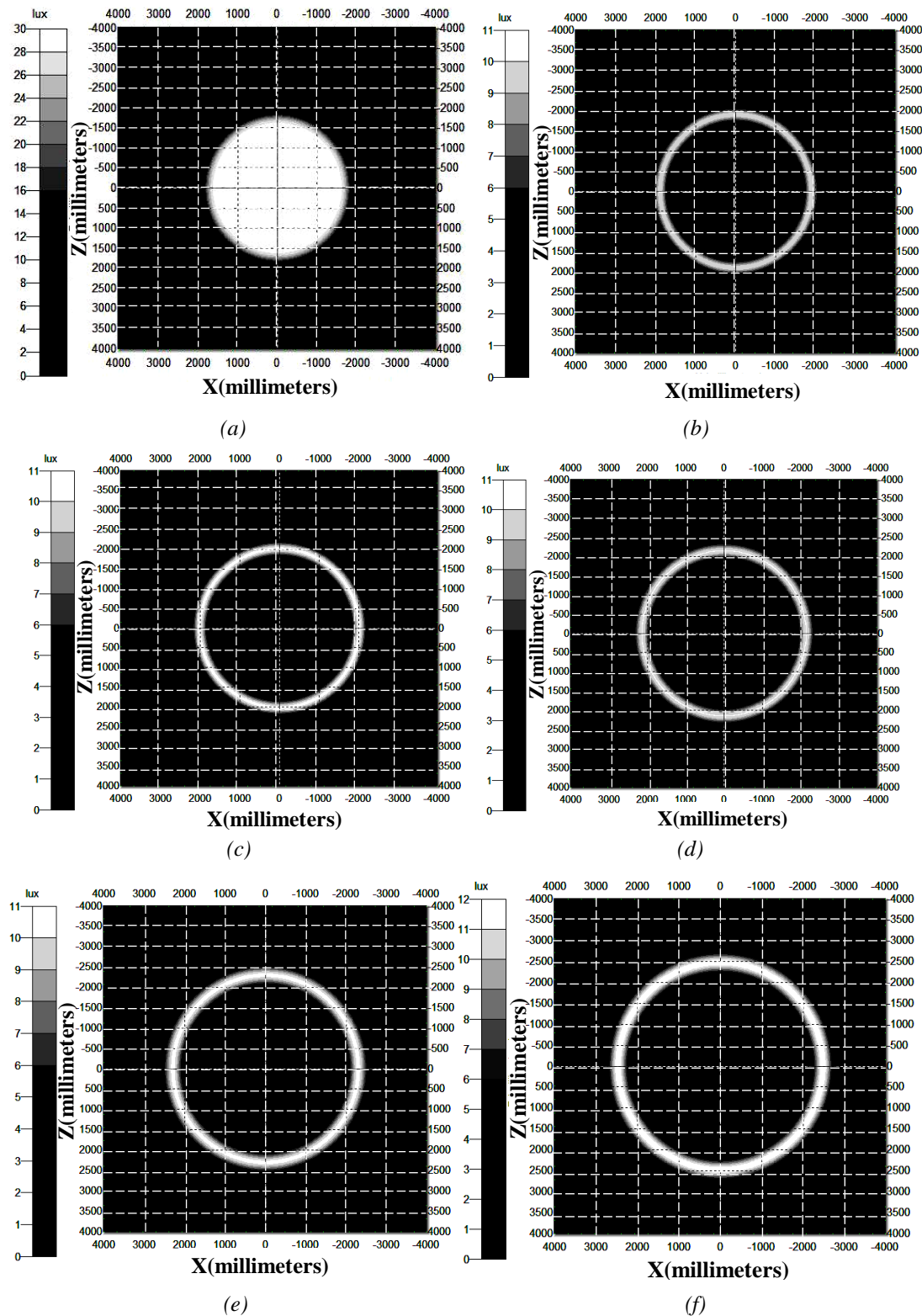

Fig. 9. Illuminance diagram with different light-emitting angle (a) 0° - 20° , (b) 20° - 22° , (c) 22° - 24° , (d) 24° - 26° , (e) 26° - 28° , (f) 28° - 30°

Combining the central lens 0 with different number of annular lenses, the whole light-emitting angle and illumination range of the optical system will be changed. By simulating and analyzing different combinations in

Tracepro software, circular uniform illumination spots with different diameters as shown in Fig. 10 can be obtained on the target plane.

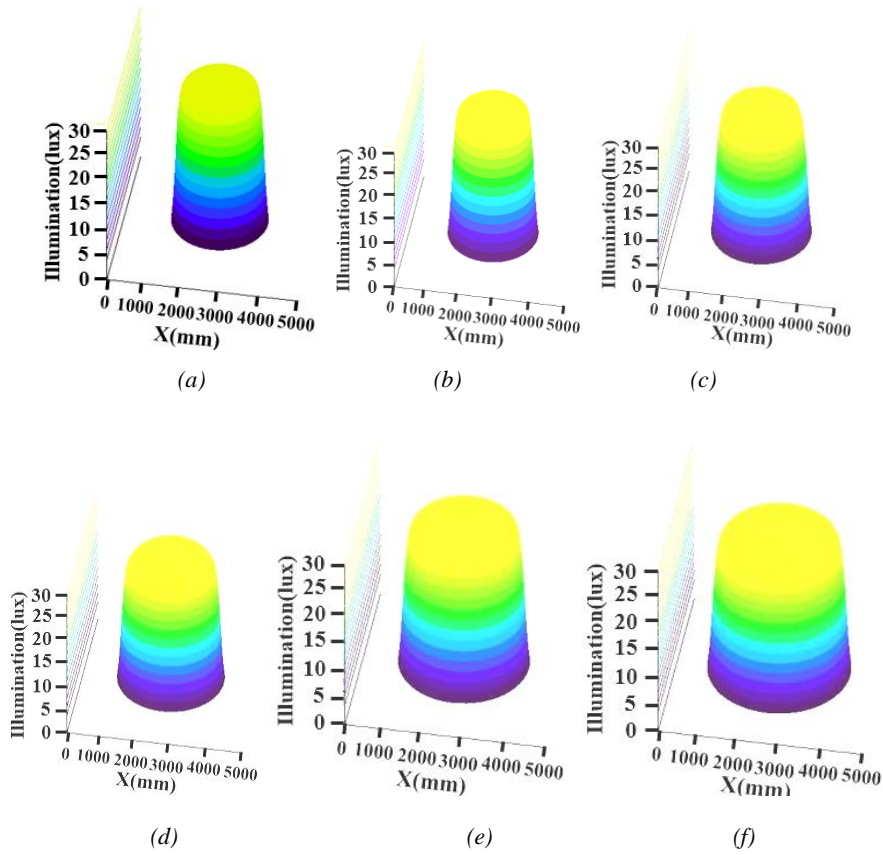

Fig. 10. 3D Illuminance diagram with different light-emitting angle (a) $0^{\circ}\sim 20^{\circ}$; (b) $0^{\circ}\sim 22^{\circ}$; (c) $0^{\circ}\sim 24^{\circ}$; (d) $0^{\circ}\sim 26^{\circ}$; (e) $0^{\circ}\sim 28^{\circ}$; (f) $0^{\circ}\sim 30^{\circ}$ (color online)

It can be seen from Fig. 9 that when the central lens is combined with the annular lenses, six illumination ranges of 20° , 22° , 24° , 26° , 28° and 30° can be realized.

Because each group of lenses can realize high-uniformity illumination in the corresponding illumination range, it can realize high-uniformity illumination in the total illumination area. Through the analysis of the illuminance uniformity in the above areas, it is found that the illuminance uniformity at a distance of 5m is greater than 0.7. The illumination module can realize high uniformity illumination at an expanded transmission distance.

At the transmission distance 1m, 5m, and 10m, this optical system can realize high-uniformity illumination in seawater by adjusting the luminous flux ratio of

different areas. When using multi-regional lighting, the luminous flux of each area corresponding to the light source is calculated according to the following formula

$$\phi_i = \int_{\theta_i}^{\theta_{i+1}} 2\pi I_i \sin \theta d\theta \quad (17)$$

where ϕ_i is the luminous flux in a certain angular interval. Calculating the luminous flux of $0 \sim 20^{\circ}$, $20 \sim 22^{\circ}$, $22 \sim 24^{\circ}$, $24 \sim 26^{\circ}$, $26 \sim 28^{\circ}$, $28 \sim 30^{\circ}$ respectively, the optimal illuminance ratio at different distances can be obtained as shown in the following Table 3.

Table 3. Luminous flux ratio of lens at different transmission distances

Transmission distance (m)	luminous flux ratio $\phi_1 : \phi_2 : \phi_3 : \phi_4 : \phi_5 : \phi_6$
1	151: 34: 38: 45: 49: 57
2	151: 39: 43: 51: 55: 63
3	151: 42: 49: 57: 64: 68
4	151: 46: 51: 60: 66: 75
5	151: 48: 55: 62: 70: 79
6	151: 52: 60: 70: 80: 88
7	151: 61: 66: 74: 84: 93
8	151: 62: 73: 81: 93: 104
9	151: 68: 76: 88: 99: 110
10	151: 74: 83: 97: 107: 119

The optical system of the high-uniformity seawater lighting module is located at 1m, 5m and 10m from the target plane, and is simulated in the Tracepro simulation software according to the corresponding luminous flux ratio. The 3D irradiance diagrams at the three typical distances are shown in Fig. 11.

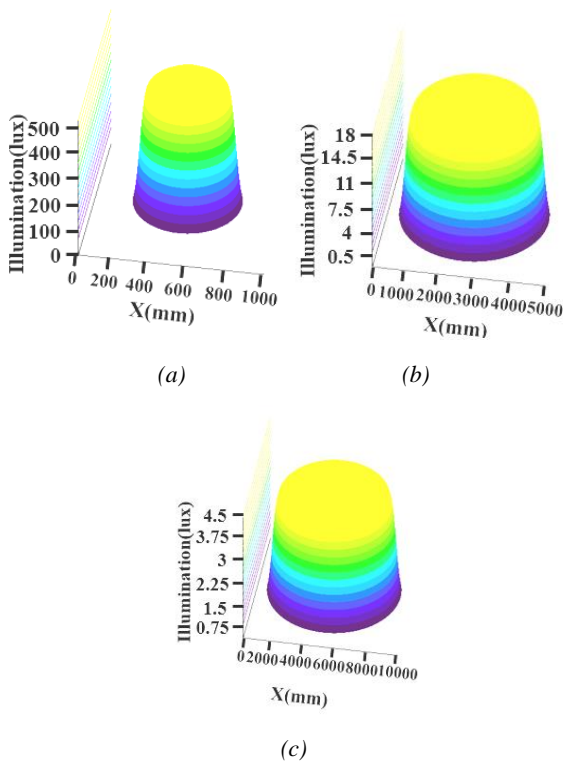

Fig. 11. Three-dimensional illumination diagram at the transmission distance of (a) 1m, (b) 5m, (c) 10m (color online)

By optimizing the designed optical system of high uniformity seawater illumination module according to the ratio of the luminous flux in Table 3, the illumination uniformity of the target plane irradiated by different transmission distances can be greatly improved. In Fig. 12, the illuminance uniformity optimized by a single lens is compared with that optimized by this design.

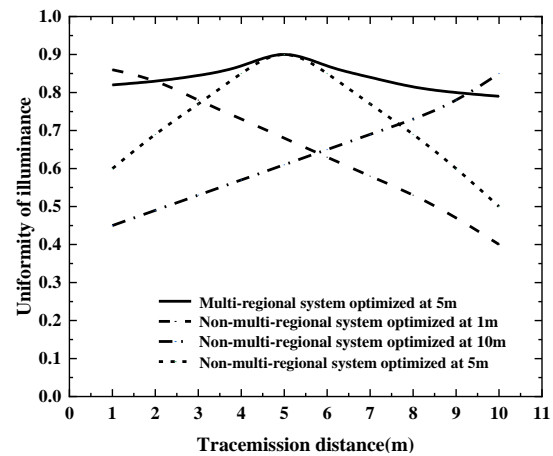

Fig. 12. The illumination uniformity at different illumination distance

In the design example of this paper, the illumination uniformity of the optimized optical system in the range of 1m to 10m exceeds 0.7, while the illumination uniformity of the optimized single lens system in the

range of 1m, 5m and 10m decreases to 0.4. It can be seen that the high uniformity seawater illumination optical system composed of a single central lens and annular lenses greatly improves the uniformity of illumination in the seawater.

5. Conclusion

In order to improve the environmental adaptability of underwater lighting optical system, the multi-regional illumination method is proposed in this paper. It is convenient to adjust the luminous flux ratio of each area at different distances based on the divided spatial illumination areas. Comparing with the illumination method of the optical system with a single lens, it is found that the proposed method can achieve higher illumination uniformity in the extended illumination distance range. This method can improve the environmental adaptability of underwater lighting fixtures and is suitable for lighting systems such as machine vision.

References

- [1] K. R. Hardy, M. S. Olsson, J. R. Sanderson, K. A. Steeves, B. P. Lakin, J. E. Simmons, P. A. Weber, Conference Oceans 2007, IEEE Xplore, 2008.
- [2] N. D. Gallo, J. Cameron, K. Hardy, P. Fryer, D. H. Bartlett, L. A. Levin, Seawater Research **99**, 119 (2015).
- [3] B. Zheng, H. Zheng, L. Zhao, Y. Gu, L. Sun, Y. Sun, Conference Oceans 2012 -Yeosu. IEEE, 1 (2012).
- [4] Sun Chuandong, Chen Liangyi, Applied Optics **21**(4), 39- (2000).
- [5] T. D. Dickey, G. W. Kattawar, K. J. Voss, Phys. Today **64**(4), 44 (2011).
- [6] X. Yi, Z. Li, Z. Liu, Applied Optics, 54(6), 1273 (2015).
- [7] Z. Zhang, X. Yin, X. Cui, H. Chang, X. Xin, Optics Communications, **510**, 127903 (2022).
- [8] R. Gray, Sea Technology **45**(12), 39 (2004).
- [9] Sheng Chih Shen, Cheng Yuan Kuo, Ming-Chung Fang, International Journal of Advanced Robotic Systems **10**(3), 183 (2013).
- [10] Lai Minfeng, N. D. Quoc Anh, Gao Jia-Zhi, Ma Hsin-Yi, Lee Hsiao-Yi, Applied Optics **54**(28), E69 (2015).
- [11] Xiangqian Quan, Xiangzi Chen, Ming Chen, Kelin Sun, Hailong Zhang, International Society for Optics and Photonics, SPIE Conference on Ocean Optics and Information Technology, 91 (2018).
- [12] Xiangqian Quan, Xiangzi Chen, Ming Chen, Kelin Sun, Chen Li, Chinese patent: CN 107657080 A, [P].2017-8-30.
- [13] Xiangqian Quan, Xiangzi Chen, Ming Chen, Kelin Sun, Chen Li, Chinese patent: CN 106793428 A, [P]. 2017-5-31.
- [14] D. Pan, Y. C. Zhang, X. F. Xie, M. J. Fan, Y. A. Chen, S. H. Yan, S. J. Yang, Lighting Research and Technology **53**(6), 569 (2021).

*Corresponding author: zhang_yc@dlpu.edu.cn